

asmproducts.com

9500 Industrial Center Drive
Ladson, SC 29456

PHONE: (+1) 843-534-1110

FAX: (+1) 843-534-1111

EMAIL: info@asmproducts.com



**INFRASTRUCTURE
SOLUTIONS**

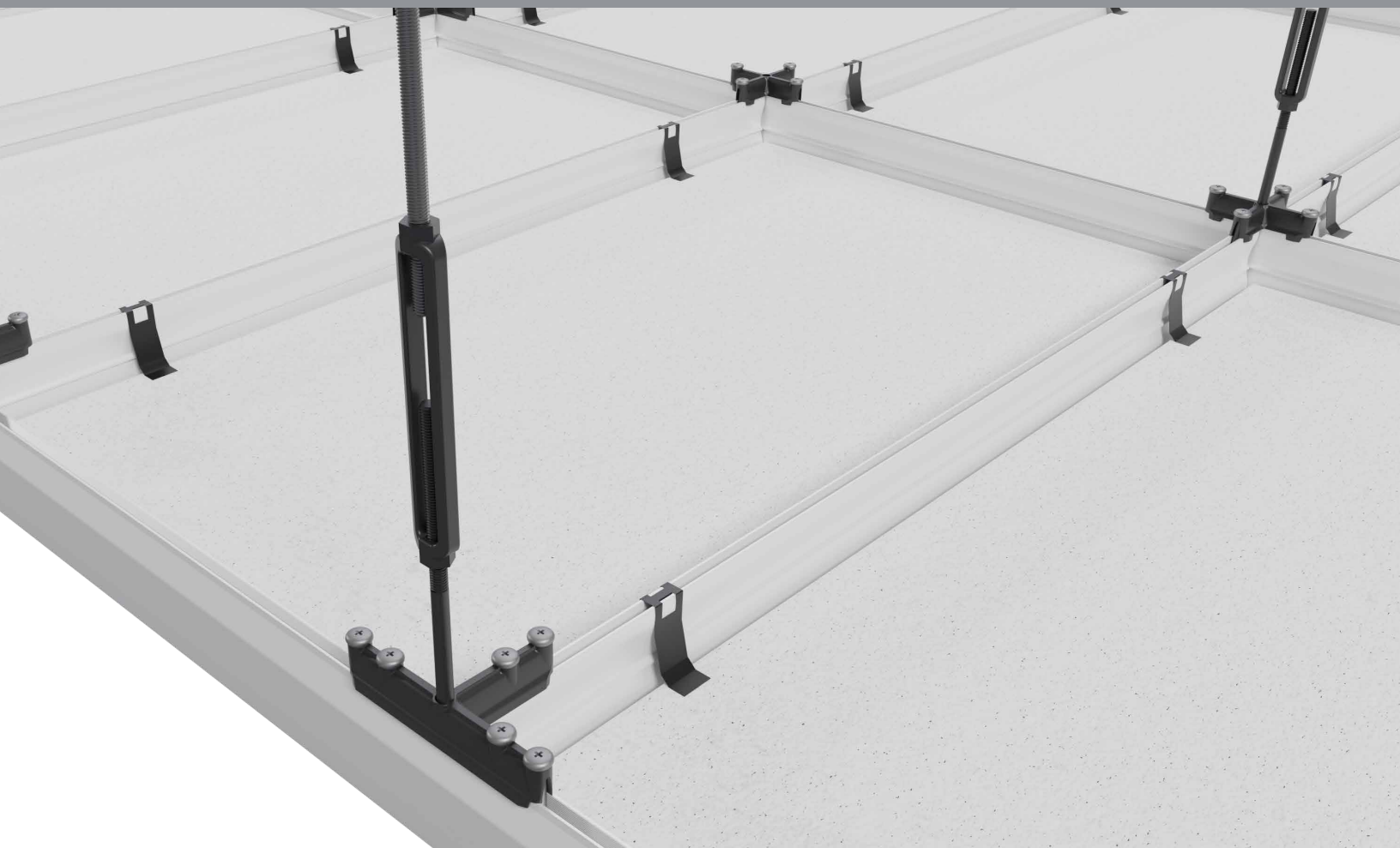

ATLAS GRID+

**ALUMINUM STRUCTURAL CEILING
GRID SYSTEM FOR DATA CENTERS**

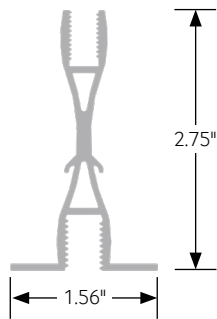
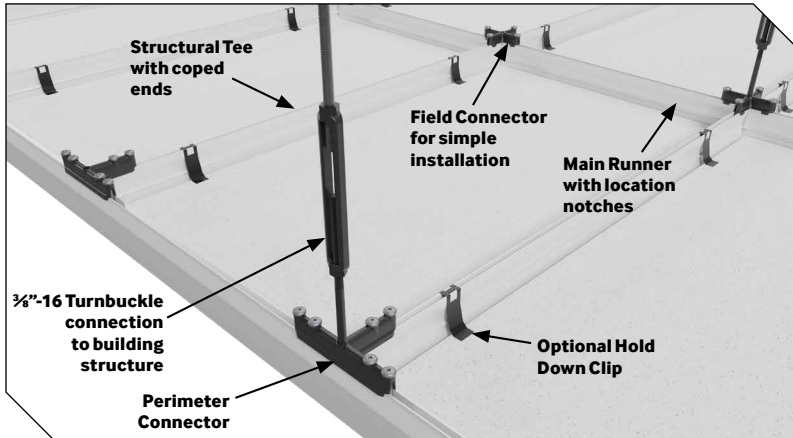

Mains, Tees and Floating Perimeter

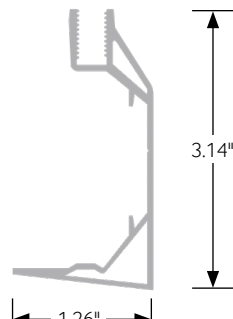

Fixed Perimeter Extrusion (optional)

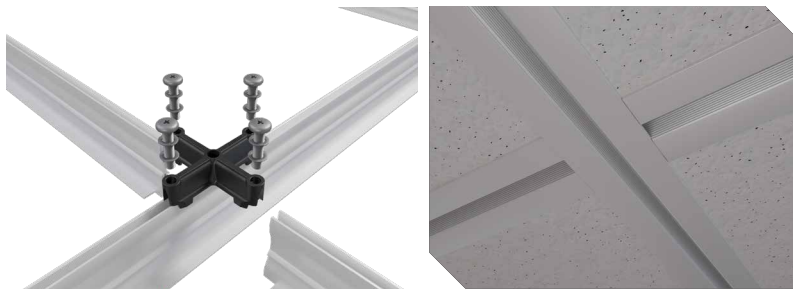

Quick and easy main and cross tee connections

Threaded 3/8" slot for easy attachment of equipment



Field Connector



Corner Connector



Hold Down Clip (optional)



Perimeter Connector



XL Connector (Main to Main)

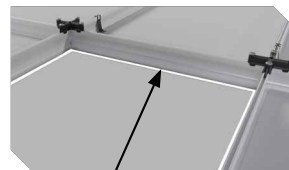

Factory Applied Gasket (optional)

GRID SPECIFICATIONS

- Pre-engineered aluminum structural ceiling grid with continuously threaded 3/8"-16 bottom slot
- Grid consists of Main Runners with notches for precise location and connection of coped Structural Tees using four screws
- Capable of supporting power modules, light fixtures, cable trays, partitions, and other accessories
- Load performance based on building connection spacing of 4 ft. on center
- Max grid point load at midspan of 475 lbs.
- Max grid uniform load of 75 lbs/ft²
- Safety Factor 2x
- System Weight:
 - 2'x2' Grid: 0.9 lb/ft²
 - 2'x4' Grid: 0.7 lb/ft²
- Grid member center to center spacing can be selected to accommodate various module sizes. (See page 4 for more information)
- All bolt connections to the top slot or bottom slot of the grid should be tightened flush to a washer with a torque value between 20 in-lbs and 30 in-lbs

CONNECTOR SPECIFICATIONS

- High Strength Cast Steel
- Corrosion Resistant
- Ribs on connector engage with grid and prevent racking
- Attaches to grid members with 3/16"-18 screws
- 3/8"-16 turnbuckles with starter rod threads into connectors on a nominal 4'x4' spacing
- All connectors are painted black

COMPONENTS

- 144" Main Runner / 144" Perimeter Angle
- 24" Structural Tee / 48" Structural Tee (nominal)
- Field Connector / XL Connector
- Perimeter Connector
- Corner Connector
- 5/16"-18 x 1-9/16" Screws w/ 3/4" Lock washer
- 3/8"-16 x 7" Turnbuckle Assembly with Starter Rod
- Ceiling Hold Down Clips (optional)
- Factory Applied Gasket (optional)
- Ceiling Tiles & ASM LED (optional)
- Threaded Rod and Connection to Building (supplied by others)

GRID OPTIONS

- Grid Color: White Black (other)
- Standard Grid Spacing Options (see P.3 for detail)
- 24" / 24" 24" / 48"
- 24 1/2" / 24 1/2" 24 1/2" / 48 1/2"
- Custom Grid Spacing Options Available

PROFILE OPTIONS

3/8"-16 Bottom Slot - Field & Floating Perimeter

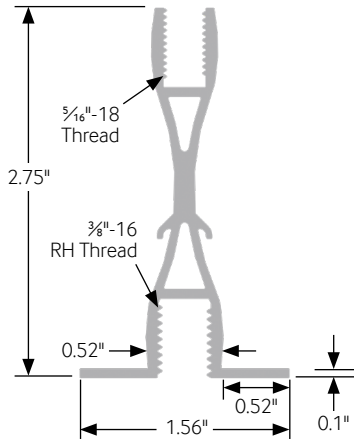

- Continuous threaded 5/16"-18 top slot
- Continuous threaded 3/8"-16 bottom slot
- Utilizes standard hardware connectors and features of Atlas Grid+

Fixed Perimeter

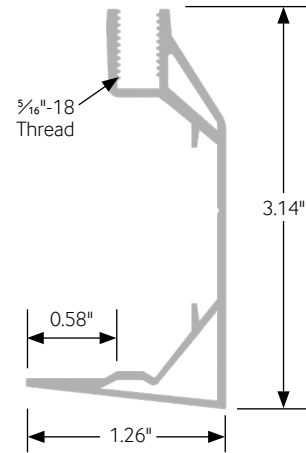

- Continuous threaded 5/16"-18 top slot
- Intended for fixed perimeter installation areas (See page 7)
- Utilizes all standard hardware connectors and features of Atlas Grid+

PERFORMANCE CRITERIA

The bottom side of the structural grid is supplied with a 3/8"-16 continuous threaded slot for mounting items directly to the grid. Refer to the table below for load performance details on the grid and connections.

STRUCTURAL TEE DEFLECTION (MIDSPAN BEAM)

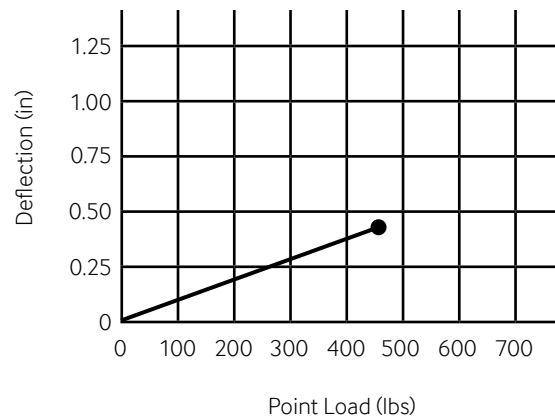
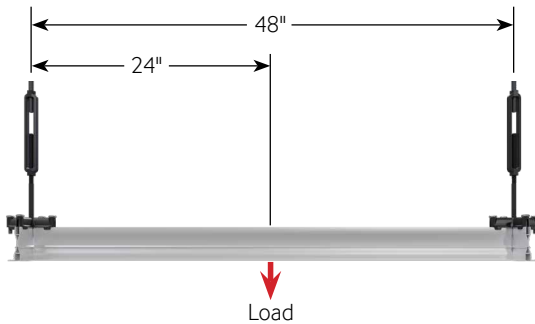

Calculate midspan beam deflection at any point below yield

$$S = \frac{WL^3}{48EI}$$

S = Deflection
 W = load
 L = 48in
 $E = 10 \times 10^6$ lbs/in²
 $I = .153$ in⁴

ON CENTER HANGER SPACING	MAX. UNIFORM LOAD	MAX. SAFE WORKING LOAD (POINT LOAD)	MIDSPAN DEFLECTION AT MAX. SAFE WORKING LOAD	SAFETY FACTOR
4' x 4'	75 lbs/ft ²	475 lbs*	.40"	2x

* Do not exceed 475 lb. load within single 4' section (between two suspension points)

475 lb point load is available at any point (or anywhere) along the Grid system (main or tee)

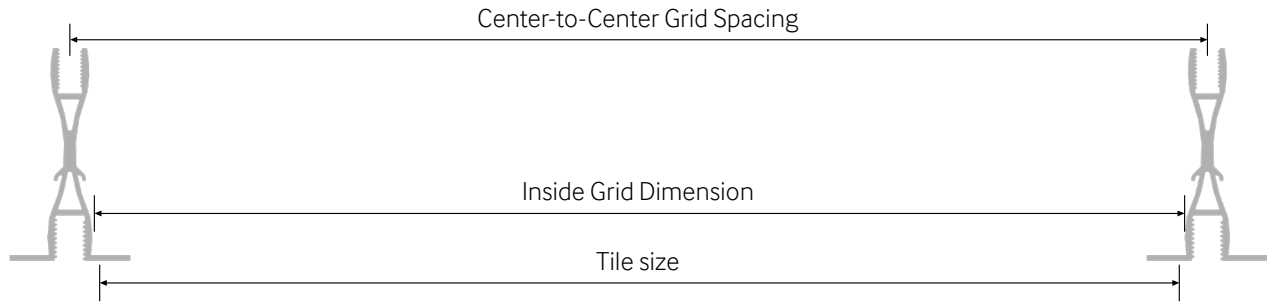

If you want the Grid Spacing to be on a 24" x 24" or 24" x 48" module size, use this table to determine tile size requirement:

Grid Profile	Grid Spacing (L x W)	Trim Size (L x W)	Hanger Spacing
3/8"-16 Bottom Slot	24" x 24"	23 7/32" x 23 7/32" +/- 1/8"	48" x 48"
	24" x 48"	23 7/32" x 47 7/32" +/- 1/8" (see example below)	48" x 48"

Note: Maximum Tile Size = Inside Grid Dimension minus 1/8". Minimum Tile Size is based on a minimum overlap on the extrusion flange of 1/8" when the tile is shifted all the way to one side.

If you want the Grid Spacing to be on a larger module size to fit standard 24" x 24" or 24" x 48" nominal tile sizes, use this table:

Grid Profile	Grid Spacing (L x W)	Trim Size (L x W)	Hanger Spacing
3/8"-16 Bottom Slot	24 1/2" x 24 1/2"	23 3/4" x 23 3/4" +/- 1/8"	49" x 49"
	24 1/2" x 48 1/2"	23 3/4" x 47 3/4" +/- 1/8" (see example below)	49" x 48 1/2"

Note: Maximum Tile Size = Inside Grid Dimension minus 1/8". Minimum Tile Size is based on a minimum overlap on the extrusion flange of 1/8" when the tile is shifted all the way to one side.

Sizing Based on 24" x 48" Grid Spacing

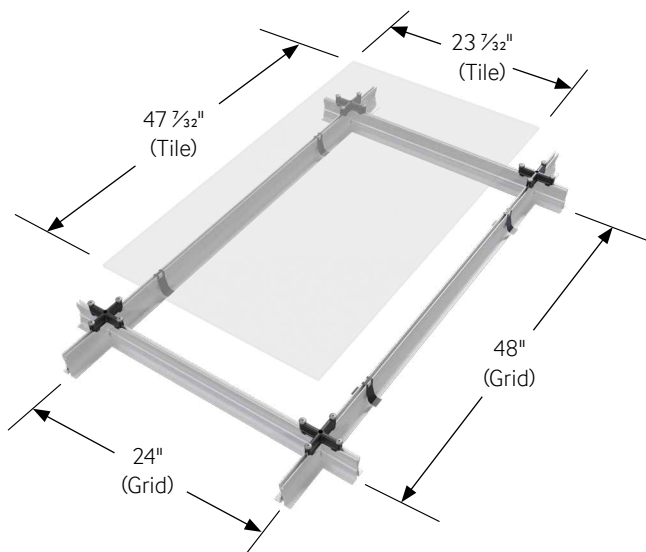

Sizing Based on 24" x 48" Nominal Tile Size

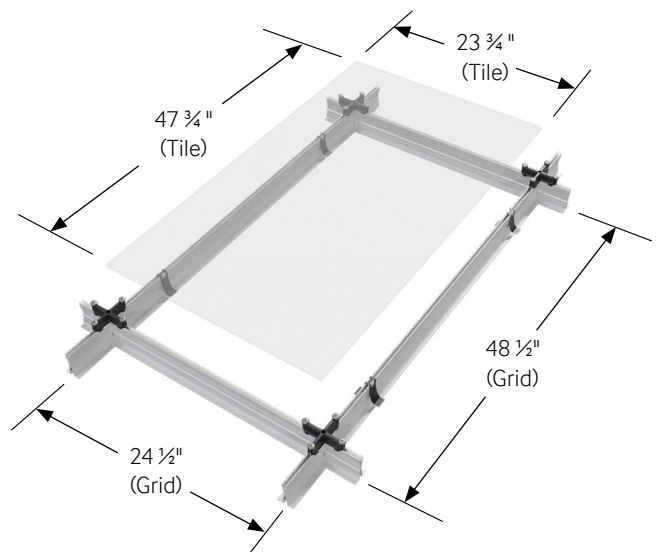

FIELD CONNECTOR ASSEMBLY - FOR CONNECTION OF MAINS TO STRUCTURAL TEES

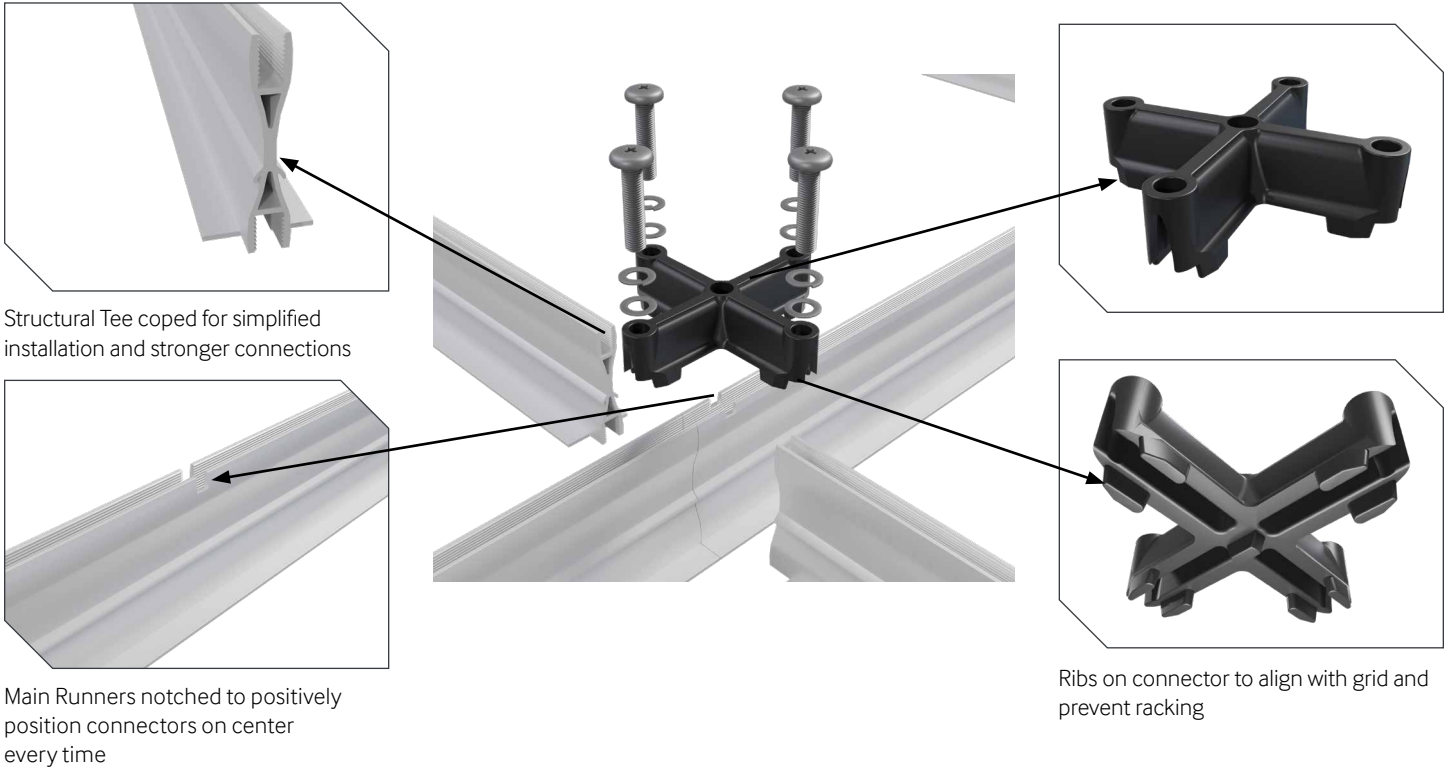

XL CONNECTOR ASSEMBLY - FOR MAIN BEAM TO MAIN BEAM CONNECTION

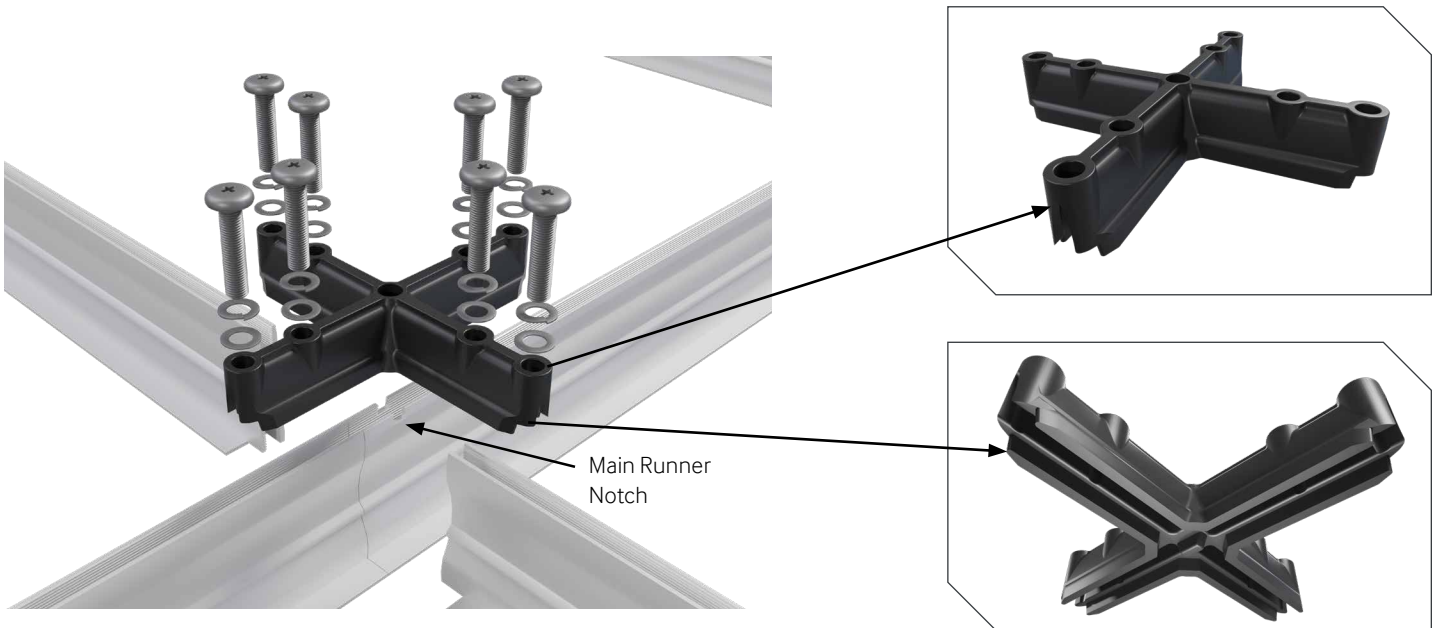

XL Connector is designed for additional support at the ends of each Main Runner.

PERIMETER CONNECTOR

Perimeter Connector can be cut to be used in various locations to connect grid together.



Corner Connector



Straight Connector



Perimeter Connector

MAIN RUNNERS AND STRUCTURAL TEES

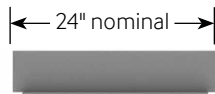

24" & 48" Structural Tees have coped ends which allow the grid to rest on the longer sections for stronger connections.

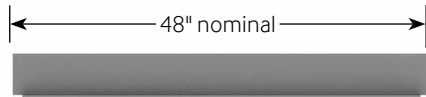

48" Structural Tee may have a notch depending on the ceiling layout.

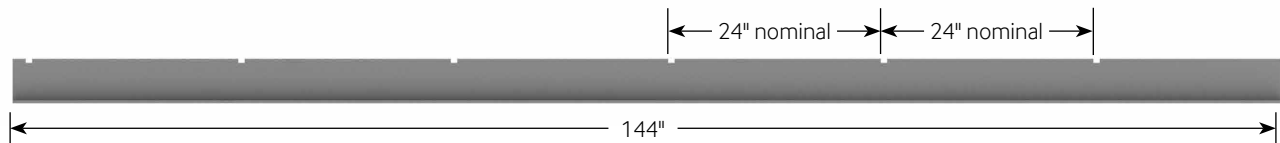

12' Main Runners are notched every 24" on center for proper alignment and spacing of the connectors.

Note: Structural Tee and Main Runner dimensions are nominal and are adjusted for custom-sized ceiling grid designs

ATLAS GRID+ END INSERT

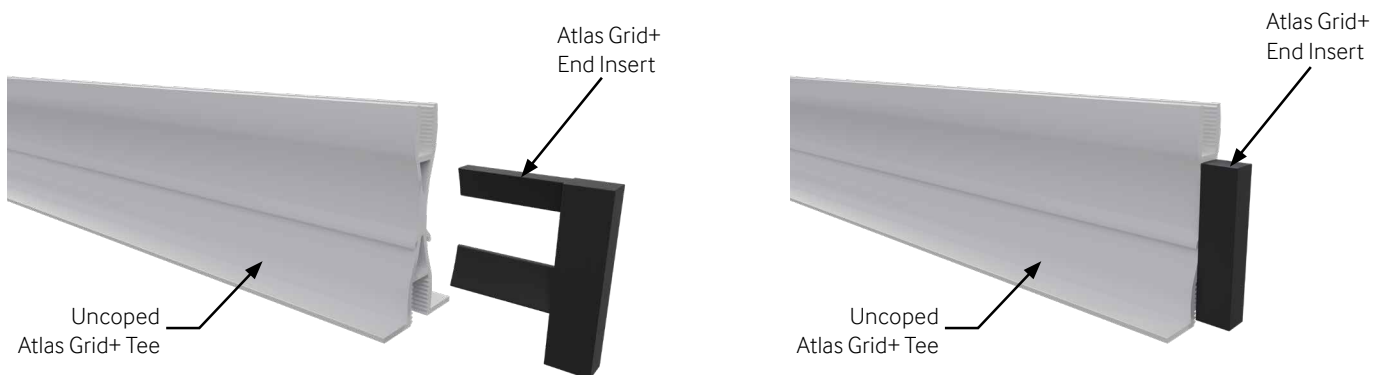

PERIMETER DETAILS

FLOATING INSTALLATION DETAIL

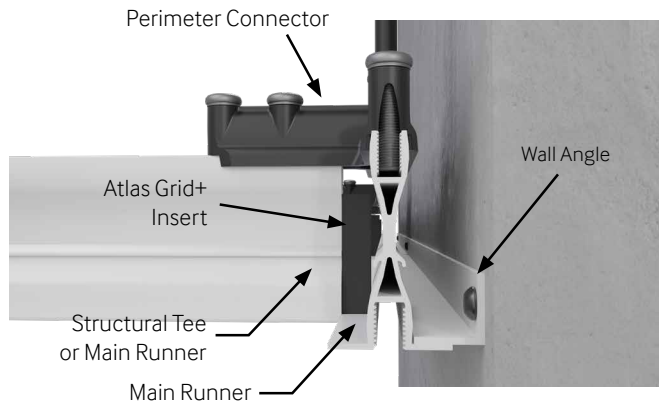

Main Runners are utilized when installing with a floating perimeter detail. When installing with a floating perimeter, Perimeter Connectors are utilized to connect a structural tee or a main runner to a floating perimeter main.

Additionally it is recommended to utilize a Wall Angle attached to the perimeter to close up the ceiling and prevent air leakage.

The Atlas Grid+ End Insert is used for additional support at the cut end of the uncoped Perimeter grid.

FIXED INSTALLATION DETAIL

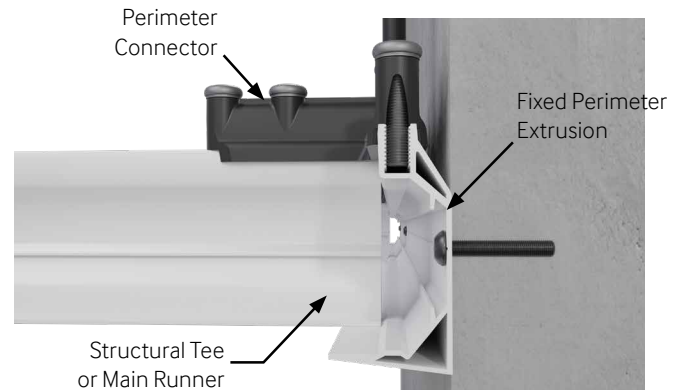

Fixed Perimeter Extrusions are designed to create a fixed perimeter detail. Fixed Perimeter Extrusions can be cut on site to desired length when assembled along perimeter walls. Fixed Perimeter Extrusions are bolted directly to the wall with appropriate fasteners for wall type.

INDIVIDUALLY SUPPORTED GRID MEMBERS WITH FLOATING PERIMETER INSTALLATION DETAIL

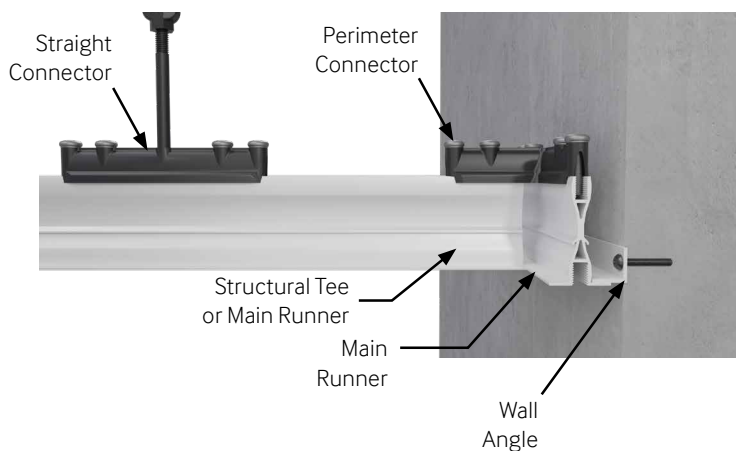

Main Runners are utilized when installing with a floating perimeter detail. When installing with a floating perimeter, Perimeter Connectors are utilized to connect a structural tee or a main runner to a floating perimeter main. A Straight connector with a rod drop is required within 12" from the perimeter on every structural tee or main runner that is connected to a floating perimeter main.

Additionally, it is recommended to utilize a Wall Angle attached to the perimeter to close up the ceiling and prevent air leakage.

TURNBUCKLE ASSEMBLY

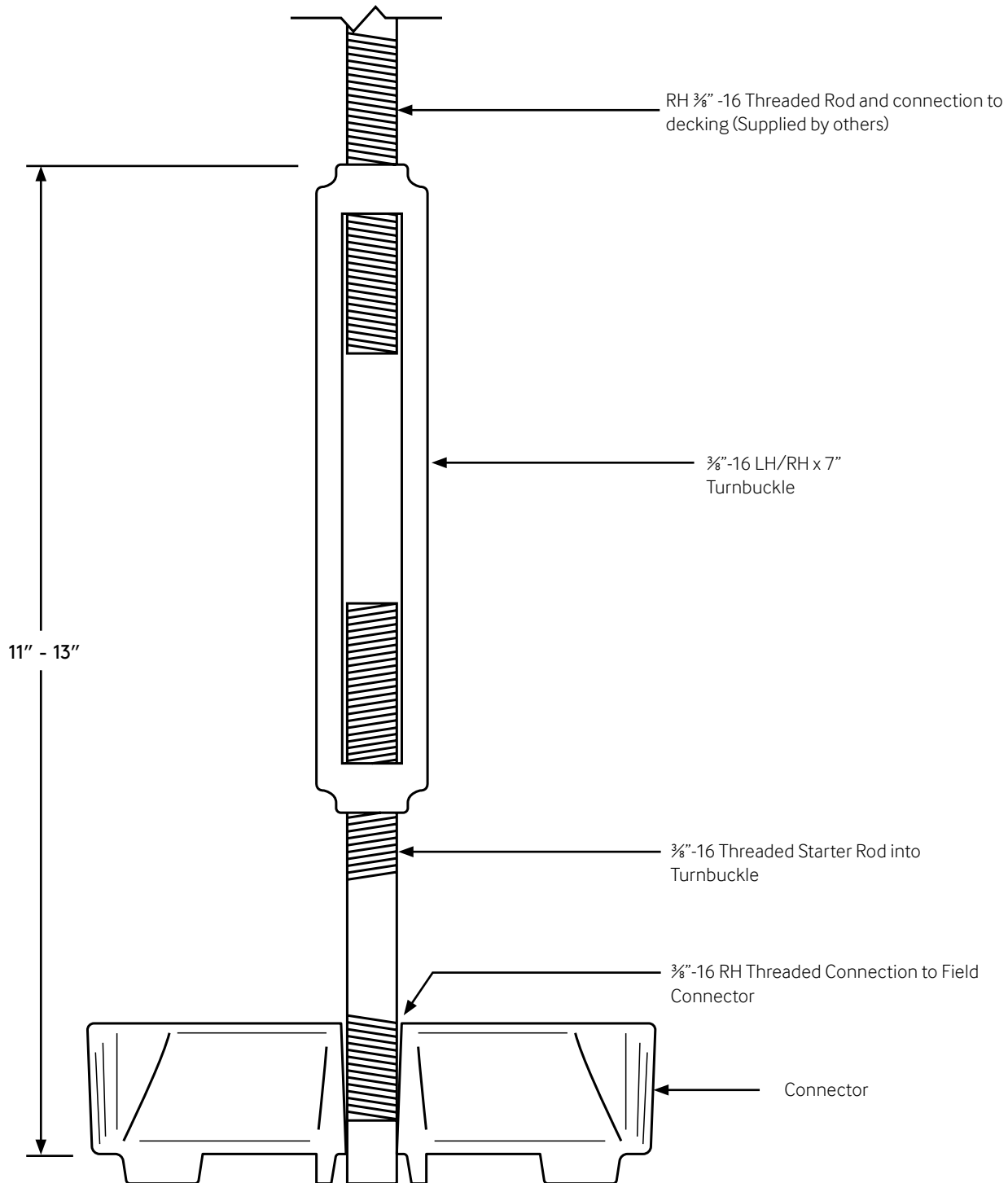

SAFETY GUIDELINES

THIS INFORMATION MUST BE SHARED WITH ALL SERVICE PROVIDERS WHO INTEND TO SUSPEND SERVICES FROM THE ATLAS GRID+ SYSTEM

Atlas Grid+ is a structural ceiling system designed to support static vertical loads. When installing services to the bottom 3/8"-16 threaded channel, the following instructions must be adhered to:

1. Atlas Grid+ is limited to a maximum point load of 475 lbs or distributed load of 75 lb/ft².
 - a. Exceeding these values may cause a failure in the system.
2. Torque the threaded rod or bolts between 20 in-lbs and 30 in-lbs. Over torquing will damage the threads of the 3/8"-16 slot reducing the load capacity of the Atlas Grid+ System.
 - a. Failure to adhere to this may result in the shearing of bottom slot threads reducing the load capacity of the Atlas Grid+ system.
3. Equal care must be taken during the installation of the Atlas Grid+ to install the top screws connecting the Atlas Grid+ to the suitable connector at a torque limit between 20 in-lbs and 30 in-lbs.
 - a. Failure to adhere to this may result in the shearing of top slot threads reducing the load capacity of the Atlas Grid+ system.
4. Only screws supplied by ASM should be used on the top slot.
 - a. Failure to adhere to this may result in the reduction of the load capacity of the Atlas Grid+ system.
5. There must be at least 1/2" thread engagement between threaded rod or bolt supporting the suspended service(s).
 - a. Failure to adhere to this may result in the reduction of the load capacity of the Atlas Grid+ system.
6. Do not impose a dynamic load on the connection to Atlas Grid+. During installation of supported services, bracing is required to prevent dynamic load on the Atlas Grid+ ceiling.
 - a. Moment forces imposed on the Atlas Grid+ system may cause failure of the connection between the services and the Atlas Grid+ system.
7. All bottom thread fixings should be completed with suitable washers.
8. Atlas Grid+ is NOT a walk-on ceiling.
9. In certain conditions the loading capacity of the Structural Ceiling System may be greater than the loading capacity of the building structure and/or means of attachment to the building structure. Consult with a licensed structural engineer to obtain site specific recommendations regarding the attachment of the Structural Ceiling System and any associated loading to the building structure.
10. Structural ceiling systems as a whole shall be analyzed and designed to local codes by a qualified engineer.



**INFRASTRUCTURE
SOLUTIONS**

9500 Industrial Center Drive
Ladson, SC 29456

PHONE: (+1) 843 534 1110

FAX: (+1) 843-534-1111

EMAIL: info@asmproducts.com

asmproducts.com



Rev: 02/12/2026

ENC: XXXXX

© 2026 ASM Modular Systems Inc