

PLAN VIEW

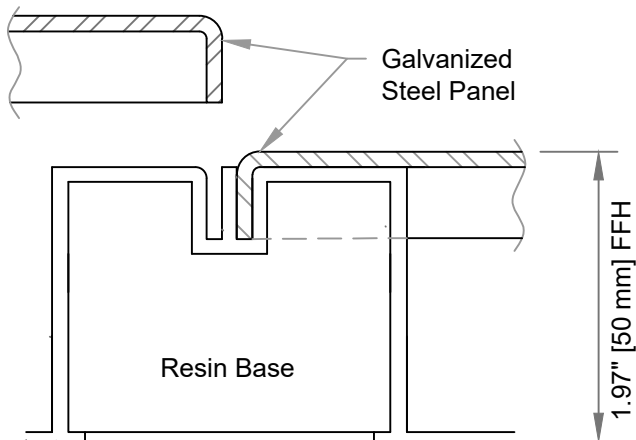

SIDE VIEW

PHYSICAL DATA

- Weight of System - 3.8 psf (18.6 kg/m²)
- Height of System - 1.97" (50 mm)

PERFORMANCE DATA

- Concentrated Live Load - 2,000 lbf (8.90 kN)
Per IBC Table 1607.1
- Concentrated Point Load - 500 lbf (2.22 kN)
Per CISCA Test Procedures, Section 1
- Uniform Live Load - 2,000 lbf (8.90 kN)
Per IBC Table 1607.1
- Ultimate Load Safety Factor - 2-to-1 Min.
Per CISCA Test Procedures, Section 2
- Rolling Loads - 10 Pass
CISCA Wheel A (3" Dia.) - 460 lb.
8" Dia. x 2" Semi-Pneumatic - 500 lb.

FINISH OPTIONS

- Bare surface galvanized steel

FEATURES

- Available at 1.97" (50 mm) FFH
- Prefabricated before shipment
- Easy to install
- Heavy-Duty quick-connect steel plates
- Easy to change layout and cable wiring
- No adhesive required
- No underlayment required
- No fasteners required