

# FS200 Enviro-Panel

## PHYSICAL DATA

- Weight of Bare Panel: 36 lb. (16.3 kg)
- Height of Bare Panel: 1.34" (34.0 mm)
- Fire Rating of Bare Panel:
  - ASTM E84: Class A Flame Spread
  - EN13501-1: A2fl-S1
  - EN13501-2: REI 30-r

## PERFORMANCE DATA

- Concentrated Load Rating: 1,250 lbs (5.56 kN)
- Uniform Load Rating: 600 psf (28.73 kN/m<sup>2</sup>)
- Ultimate Load Rating: Min. 2,500 lbs (11.12 kN)
  - Safety Factor: 2-to-1 Min.
- Impact Load Rating: 150 lb. (68 Kg)
- Rolling Load Rating:
  - CISC Wheel A (10 Pass): 1,000 lbs (4.45 kN)
  - CISC Wheel B (10K Pass): 800 lbs (3.56 kN)

## FINISH OPTIONS

- HPL Tile (1 / 16")
  - Integral Trim or Smart Trim
- Vinyl Tile:
  - VPT "Con-Tile" (Static Conductive)
  - VPT "Stat-Tile" (Static Dissipative)
- RubberTile:
  - Antistatic
  - Standard
- Bare Surface
- Bare Corner-Lock
- Contact ASM for other tile options such as Bamboo, Cork, Ceramic, Wood, Stone, etc.

## UNDERSTRUCTURE OPTIONS

- Free Standing - Stringerless
- Corner-Lock
- Rigid Grid Bolted Stringers
  - 2' x 2' System or 600mm x 600mm System
  - 2' x 4' System or 600mm x 1200mm System
  - 4' x 4' or 1200mm x 1200mm Basketweave System

## FEATURES

- Available in (24") or (600mm) Size
- Powder Coat Epoxy Paint Finish
- Welded Steel Construction (Recycled)
- Full-Hard Steel Top Sheet
- Full-Strength, Deep Drawn Corners
- Light Weight Cementitious Fill (Recycled)

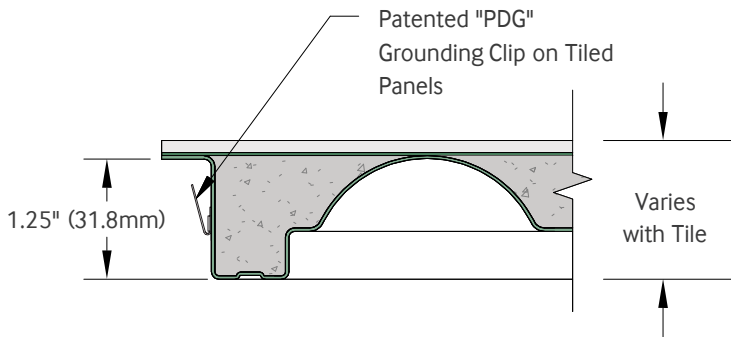

**TILE COVERED PANEL**

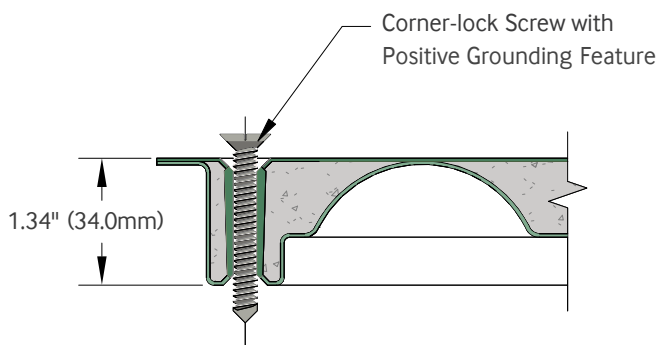

**BARE CORNER-LOCK PANEL**

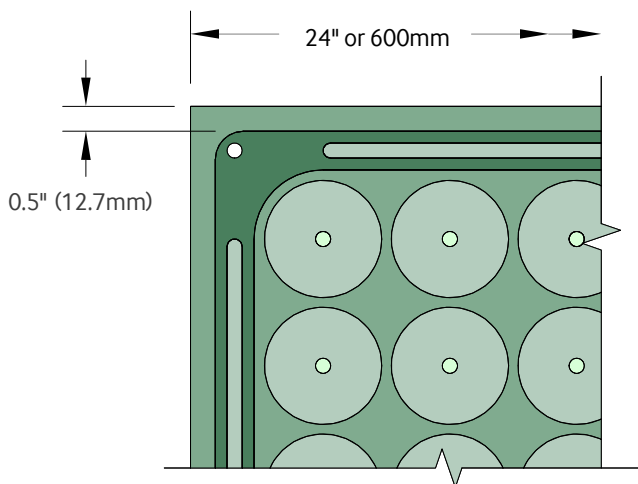

**PARTIAL BOTTOM VIEW**

(Date of Revision: 3/3/2026)