

TILE COVERED PANEL

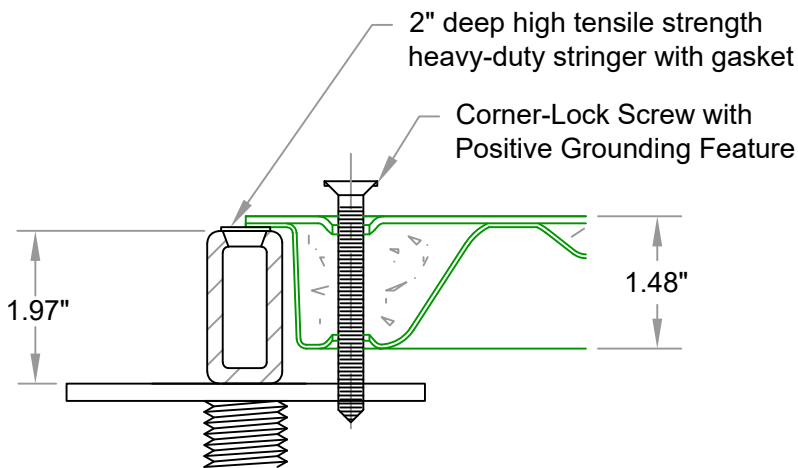

BARE CORNER-LOCK STRINGERED SYSTEM

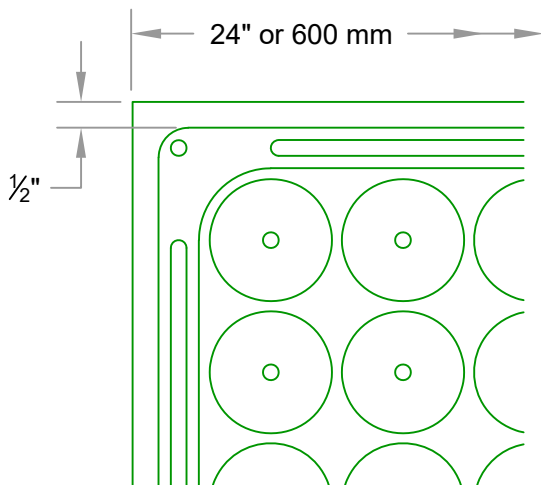

PARTIAL BOTTOM VIEW

PHYSICAL DATA

- Weight of bare panel - 56 lb.
- Height of bare panel - 1.48"
- Fire rating of bare panel:
Class A Flame Spread
Non-Combustible Materials

PERFORMANCE DATA

- Concentrated Load Rating - 4,000 lbf (17.79 kN)
- Ultimate Load Rating - 12,500 lbf (55.60 kN)
- Impact Load Rating - 300 lb (136 Kg)
- Rolling Load Rating:
CISCA Wheel A (10 Pass) - 3,100 lbf (13.79 kN)
CISCA Wheel B (10K Pass) - 2,700 lbf (12.01 kN)

FINISH OPTIONS

- HPL tile:
Integral Trim
- Vinyl tile:
Conductive
Static dissipative
- Custom

UNDERSTRUCTURE OPTIONS

- Rigid Grid Bolted Stringer System (1.97" deep, high tensile strength, heavy-duty stringer with conductive, air sealing gasket):
2' x 2' system
2' x 4' system
4' x 4' Basketweave system

FEATURES

- Available in 24" or 600 mm size
- Powder coat epoxy paint finish
- Welded steel construction
- Full-hard steel top sheet
- Full-strength, deep drawn corners
- Light weight cementitious fill recycled