

**TILE COVERED  
CORNER BOLTED PANEL**

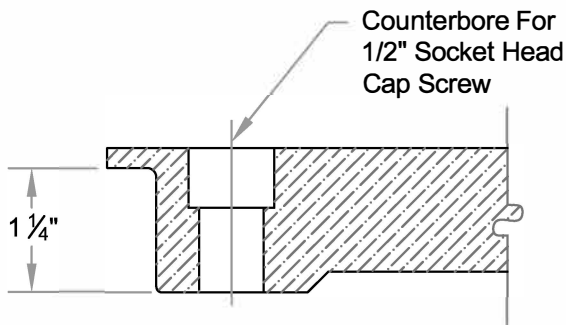

**BARE SURFACE  
CORNER BOLTED PANEL**

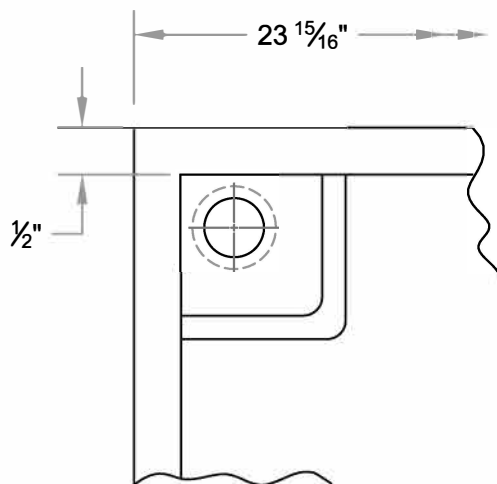

**PARTIAL BOTTOM VIEW**

**PHYSICAL DATA**

- Weight of bare panel - 72 lb.
- Height of bare panel - Varies
- Fire rating of bare panel:  
Class A Flame Spread  
Non-Combustible Material

**PERFORMANCE DATA**

- Concentrated Load rating - 8,000 lbf (35.7 kN)
- Uniform Load rating - 2,500 psf (11,205 kg/M<sup>2</sup>)
- Ultimate Load rating - 20,000 lbf (89 kN)  
Safety Factor - 2.5-to-1 Min.
- Impact Load rating - 1,000 lb. (454 Kg)
- Rolling Load Rating:  
CISCA Wheel C (10 Pass) - 8,000 lbf (35.7 kN)

**FINISH OPTIONS**

- HPL tile (1/16" or 1/8")  
ASM "Smart-Trim", "Dura-Trim" or "Mono"
- Vinyl tile:  
VPT "Con-Tile" (static conductive)  
VPT "Stat-Tile" (static dissipative)
- Rubber tile:  
Anti-static  
Standard
- Bare surface
- Corner bolted (bare or with tile)

**UNDERSTRUCTURE OPTIONS**

- Corner-Bolted
- Rigid Grid bolted stringers:  
2' x 2' system  
2' x 4' system  
4' x 4' Basketweave system
- Pedestals are sized to suit application

**FEATURES**

- Available in 24" or 600mm size
- Epoxy paint or Mill finish
- Recycled material content = 100%