

Section 8

Drop Impact Load Test

Purpose:

The purpose of this test is to show the effect upon access floor panels and supporting understructure system(s) when subject to impact from heavy loads being accidentally dropped onto the floor panel.

Preparation:

Test(s) shall be performed on three (3) randomly selected bare panels placed on an understructure support system that is configured identical to an installed system. Any stringers, coatings, gaskets, pads, clips, fasteners, locking devices or other materials normally used shall be configured identical to that provided in an installed system. The test mock-up configuration shall be at a finished floor height suitable for the system being tested. A safety-restraining device may be utilized for load constraint to prevent possible injuries, providing it does not restrict the purpose of the test. The load to be dropped shall be either a single hard object or objects placed inside a rigid container that will not flex or distort during the impact of the test. The load shall be dropped vertically from a given height onto the center of a steel "impact" plate of not less than one-half inch (1/2") [12.7 mm] thick x eight inches (8") [20.3 mm] square that is placed centrally on top of a one inch (1") [25.4 mm] square steel indenter not less than one-half inch (1/2") [12.7 mm] thick.

Test Procedure:

1. The load shall be dropped, free fall from a height of 36" (914 mm) measured from the top of the steel "impact" plate to the underside of the weight being dropped.
2. Two one-panel mock-up assemblies shall each be tested with the load target directly in the center of each panel.
3. Two one-panel mock-up assemblies shall each be tested with the load target directly on the midpoint of the edge of each panel.
4. Two one-panel mock-up assemblies shall each be tested with the load target at the discretion of the testing lab to determine the weakest points.
5. After completion of the impact test on each panel, one panel shall be tested according to Section 1: Concentrated Loads at the point of impact, and the other shall be tested according to Section 2: Ultimate Load. (The weights dropped on panels for Concentrated and Ultimate Load testing may be different.)

NOTE: Panels or understructure systems which are not symmetrical, shall be tested in accordance with the above procedure and then re-tested with separate mock-up materials installed (rotated) 90° to the first test mock-up.

Report:

1. Reference of testing procedures described herein by CISCA A/F section number shall be included in report.
2. All apparatus, equipment, instrumentation, accuracy ranges, etc. shall be described including equipment calibration/certification dates.

3. Materials tested and any load restraining device, if used, should be fully described in verbiage or referenced to manufacturer's drawings and part numbers, containing the following information:
 - a. Panels:
 - Material(s) of panel construction.
 - Weight, nominal dimensions and thicknesses.
 - b. Stringers and Pedestals:
 - Material(s) of construction.
 - Weight, nominal dimensions and thicknesses, including fasteners, gaskets, coatings, clips, etc.
 - c. Other:
 - Fully describe gaskets, pads, or other items utilized in the system.
4. Amount of weight dropped onto system.
5. Height from which weight was dropped onto system.
6. For each panel subjected to testing under Section 1, report the impact weight, the concentrated load and deflection realized. For each panel tested according to Section 2, report the impact weight and ultimate load achieved.

Test Setup:

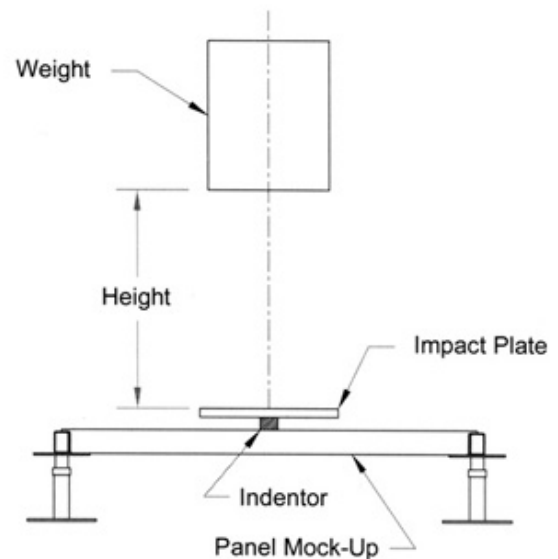

SETUP FOR DROP IMPACT LOAD TEST

(Fig. 7)