

# Section 3

## Rolling Loads

### Purpose:

To determine the durability and/or deformation of access floor systems when exposed to commercially anticipated caster traffic using a specified load.

### Preparation:

1. Each test shall be performed on a mock-up consisting of a minimum of three (3) randomly selected bare panels installed on a support understructure system identical to the configuration of a normal field installation with a finished floor height of 12" or the maximum height of the system, whichever is less.

A restraining frame which laterally supports the mock-up assembly may be utilized to protect equipment or for personnel safety, provided said frame is constructed to not interfere with the panels or supporting understructure and provides clearance from any point of the mock-up prior to the start of test.

Testing apparatus shall be designed to impose caster rolling loads directly on the mock-up system, with the load traversing in a fixed path on the three panels being tested. Dampening of mock-up, load, caster wheel applicator, load carriage or load bed is prohibited.

2. Loads shall be directly imposed through caster wheels manufactured in accordance with attached drawings.

### Test Procedures:

1. Each mock-up assembly shall be subjected to the imposed caster rolling load traversing the center panel along a fixed path at a speed of 100 FPM (0.5 m/s) (+ - 10%), at a minimum stroke distance of 36" (914 mm) or panel dimension plus 12 inches (305 mm).
2. The fixed paths for the imposed caster rolling loads are defined as follows, with the center of the wheel width dimension being the locator of the path:  
Path "1"  
Fixed path traversing across mock-up panels at panel centers.  
Path "2"  
Fixed path traversing across all three mock-up panels, along a line inboard and parallel from the outer edge as determined by the "weakest point." The "weakest point" is to be determined by the certifying independent testing agency and is defined as the path which yields the greatest top surface deformation under rolling loads as determined by this section.
3. Wheel A (See box with Rolling Load Wheel Specifications) shall be applied to separate mock-ups for each fixed paths 1 & 2 for ten (10) passes with deformation measurements at start and upon completion.  
Wheel B and Wheel C shall be applied to separate mock-ups for each fixed paths 1 & 2 for 10,000 passes with deformation measurements at start and upon completion of 500, 5,000 and 10,000 passes.
4. Measurement(s) and reference locations prior to test shall be

taken as follows:

- a. The center panel, prior to start of test, shall be measured for overall flatness utilizing a 32" (813 mm) long straightedge. The straightedge shall be placed parallel with each panel edge, flush with the edge or not more than 12" (12.7 mm) inboard from the edge. The straightedge shall also be placed along the diagonal in each direction. Measurement shall be taken at each straightedge location (6 locations) at the maximum variation and recorded and located for reference. (Note: If the panel configuration has an upward "crown", it shall be so measured and reported.)
  - b. Prior to the start of test, the center panel, at points along the proposed caster path, shall be measured for local variation utilizing a 6" (152 mm) long straightedge. The largest six (6) variations shall be measured, recorded and located for reference.
5. Measurement upon completion of test:
    - a. The center panel, upon completion of test shall be measured in an identical manner as described in 4a above. The maximum beam deformation measurements (6 required) shall be recorded and located for reference.
    - b. Upon completion of test, the center panel shall be measured in an identical manner as described in 4b above. The maximum local deformation measurements (6 required) shall be measured, recorded and located for reference.
  6. Actual vertical wheel force shall be verified with a load cell or similar device before the start of each test.
  7. A separate mock-up assembly shall be utilized for each wheel type and path tested.
  8. Panels or understructure systems which are not structurally symmetrical, shall be tested in accordance with the above procedure and then re-tested with separate mock-up materials installed (rotated) 90° to the first test mock-up.

### Report:

1. Reference of testing procedures described herein by CISCA A/F section number shall be included in report.
2. All apparatus, equipment, instrumentation, accuracy ranges, etc. shall be described including equipment calibration/certification dates.
3. Materials tested, mock-up configuration(s), and restraining frames, if used, should be fully described in verbiage or referenced to manufacturer's drawings and/or part numbers, either containing the following information:  
Panels:
  - Material(s) of panel construction.
  - Weight, nominal dimensions and thicknesses.Stringers and Pedestals:
  - Material(s) of construction.
  - Weight, nominal dimensions and thicknesses, including fasteners, gaskets, coatings, clips, etc.Other:
  - Fully describe gasketing, pads, or other items utilized in the system.
4. For the 10,000 Pass test, the results of the test with only one wheel shall be reported.
5. Panel deformation shall be reported for each test and each path in accordance with the attached report format. Each

listing of data shall indicate the following:

Wheel# (A, B or C)

Imposed Load (lbs) (N)

Fixed Path (1 or 2)

Number of Passes

\*Deformation Reported (To nearest .001" [0,025 mm])

\*Deformation reported shall be the maximum measurement for both beam deformation and local deformation.

6. Any visible structural damage to any mock-up component shall be reported.

## **Rolling Load Wheel Specifications**

### **10 pass test**

#### **Wheel A -**

3" diameter x 1<sup>13</sup>/<sub>16</sub>" width (76.2 mm diameter x 46.0 mm width)

Tread type: hard rubber or phenolic material, maximum .062" (1.57 mm) crown

### **10,000 pass test**

#### **Wheel B - For loads up to 1500 pounds (6.675 kN)**

6" diameter x 2" width

(152 mm diameter x 50.8 mm width)

Tread Type: molded urethane tread, maximum <sup>1</sup>/<sub>16</sub>" (1.59 mm) crown

#### **Wheel C - For loads over 1500 pounds (6.675 kN)**

10" diameter x 4" width

(254 mm diameter x 102 mm width)

Tread Type: molded urethane tread, maximum <sup>1</sup>/<sub>16</sub>" (1.59 mm) crown

### Section 3: Rolling Loads

- Fixed Path 1 or 2
- Deformation Readings
- Beam & Local
- Or panel dimension plus 12" (305 mm) to length of stroke

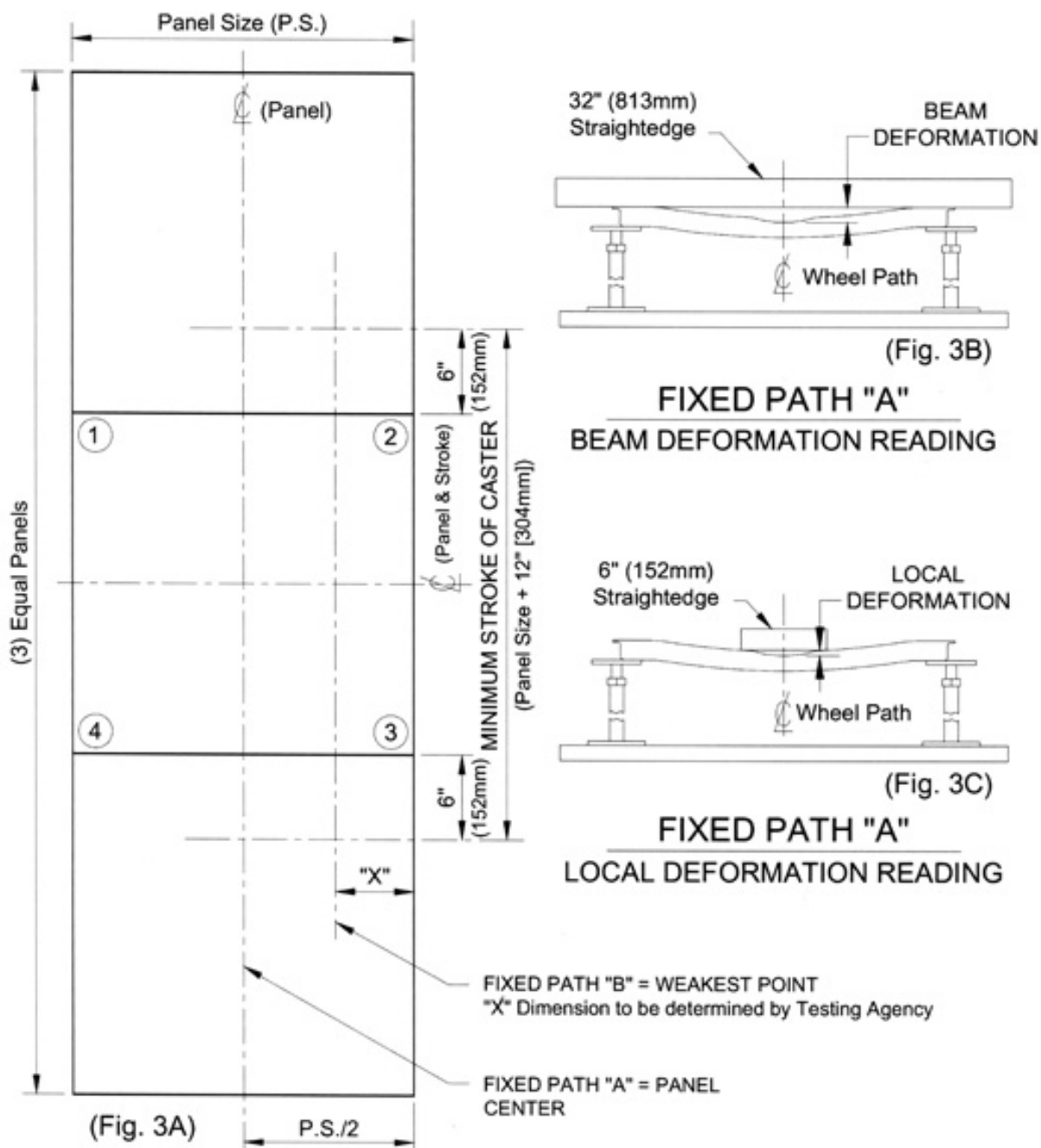

SETUP FOR ROLLING LOAD TEST  
(Fig. 3)

Rolling Load Drawings Section 3:

- Wheel A
- Wheel B
- Wheel C

**WHEEL "A"**

3" (76mm) Dia. x  
1 13/16" (46mm) Wide  
Phenolic Tread  
With 1/16" (1.5mm) Crown

(Fig. 4A)

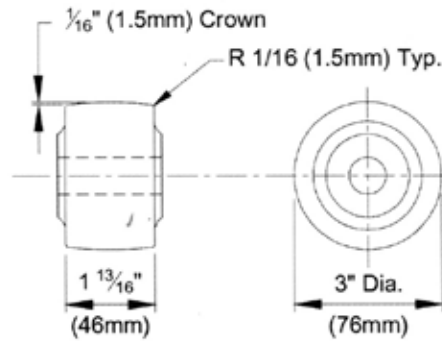

**WHEEL "B"**

6" (152mm) Dia. x  
2" (51mm) Wide  
Urethane Tread

(Fig. 4B)

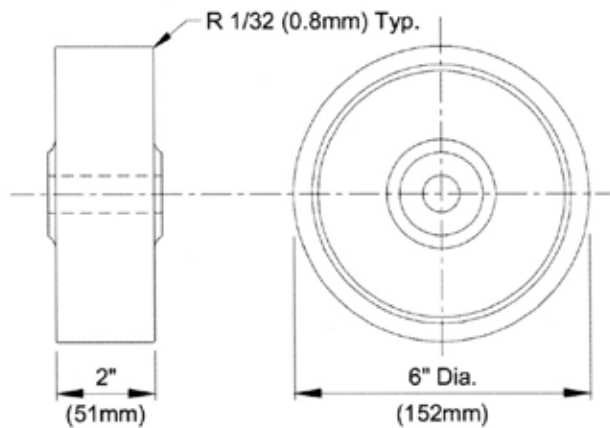

**WHEEL "C"**

10" (254mm) Dia.  
3" (76mm) Wide  
Urethane Tread

(Fig. 4C)

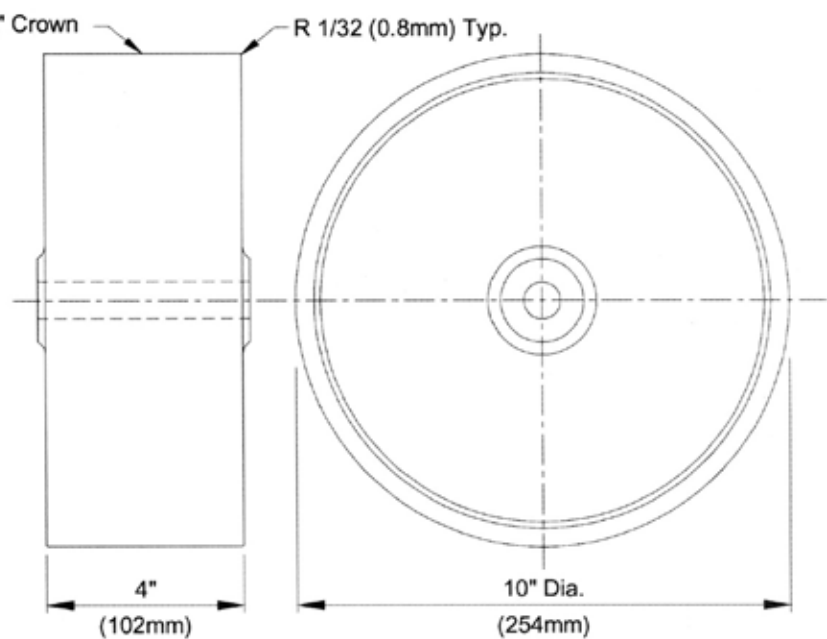

(Fig. 4)